

Hydr. driven Piston Pump KIP 25 with S-Tube technology



Application

Hydraulically driven piston pumps, with S-Tube technology, are well proven in the heavy construction world. More than 100.000 pumps are on duty with the 100% satisfaction of the operator.

To use this kind of pump in industrial applications is the logic consequence out of this.

The **KLEIN KIP 25** is able to transport difficult sludges and slurries as they are:

Biomass:

- Food with overtime storage or food waste from restaurants. With foreign particles up to 150 mm length and a dry solid content up to 25 % are pumpable.
- Substrate from Bio Methanisation plant, with high content of inorganic material like plastic, wooden sticks, metal or stones.

Waste Water Treatment Plants:

- mechanical dewatered biosolids from belt presses, centrifuges or chamber filter presses with a dry solid content up to 35 % are pumpable

Artificial Fuel:

- High calorific value fuel with a viscosity from liquid to pasty.

Mining and Tunneling:

- Pumping Tailings from Mineral ore mines into landfill or back into the mine.
 - Muck pumping out of the Tunnel construction.
-

Technical Data KIP 25

Pump Unit

Max. theo. Delivery capacity	20,0	m ³ /h
Max. Pump cycle	13,0	strokes / min
Delivery cylinder (Dia x Stroke)	180 x 1.000	mm
Delivery cylinder volume	25,4	ltr
Max. hydraulic pressure	180,0	bar

KIP 25

Drive cylinder (D _{piston} /D _{rod} x Stroke)	125/80 x 1.000	mm
Max. delivery pressure	68,0	bar

KIP 25 HP

Drive cylinder (D _{piston} /D _{rod} x Stroke)	140/80 x 1.000	mm
Max. delivery pressure	85,0	bar

KIP 25 SHP

Drive cylinder (D _{piston} /D _{rod} x Stroke)	180/90 x 1.000	mm
Max. delivery pressure @ 170 bar hydr. pressure	130,0	bar

Hydraulic Power Unit

- Oil tank 600 l with integrated return filter
- Oil pan 600 l as support frame and drainage valve
- Oil level control indicator with thermo element, 2 cleaning openings, drainage valves
- Oil pumps for piston pump from von BOSCH Rexroth
- Gear pump for oil cooling circuit with high pressure relieve valve
- Oil cooler with E-Motor 400 V / 50 Hz
- E-Motor 15 – 75 kW and 90 – 315 kW; 400 V / 50 Hz; 1.480 min⁻¹

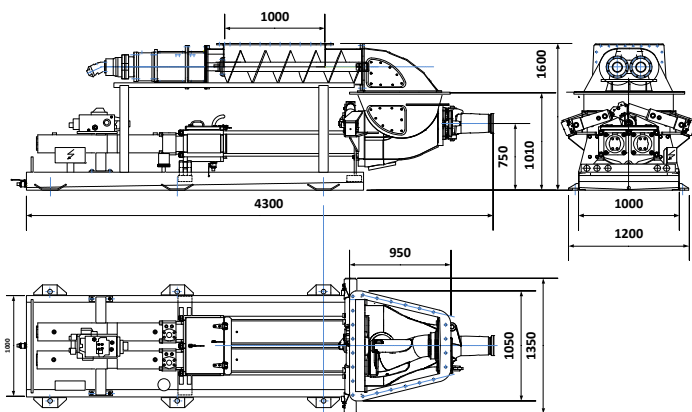

Dimensions on drawing are similar

Performance Diagram

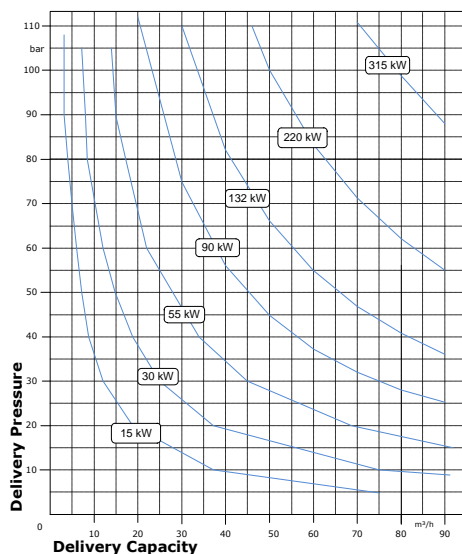

KLEIN

Klein GmbH
 Messerschmittstrasse 12
 89343 Jettingen-Scheppach – Germany
Telefon: +49-(0)-8225-95992-0
 Telefax: +49-(0)-8225-95992-55
 E-Mail: info@kleingmbh.de
 Internet: www.kleingmbh.de

Klein of America Inc.
 4293 County Rd. 46
 Maidstone, ON N0R 1K0 – Canada
 E-Mail: info@kleingmbh.com
 Internet: www.kleingmbh.com